



# GPS-50-2

## GPS Speed and Bus Interface Module

**IMPORTANT NOTE!** When used to operate a cruise control, see the special mounting requirements on the bottom of page 13.  
 The GPS-50-2 cannot connect to a BIM-01-2 series.  
 The two units cannot send similar data at the same time

### Your new GPS-50-2 includes:

GPS module



394192 - BIM-XX-2 interface harness



Optional  
640041- Remote antenna



### Table of Contents:

Product Overview	Page 2
Installation: Wiring Overview	Page 3
Installation: Wiring using a BIM cable (no BIM-01-2 present)	Page 4
Installation: Wiring standalone (individual gauge, or BIM-01-2 present)	Page 5
Installation Overview	Page 6
Setup / Clock Setup: VFD3 or VFD3X without a BIM-01-2	Page 7
Setup / Clock Setup: VHX without a BIM-01-2	Page 8
Setup / Clock Setup: HDX or RTX without a BIM-01-2	Page 9
Setup: Standalone speed output only	Page 10
Setup: Calibration setups for standalone speed only	Page 11
Cruise Operation	Page 13
Setup: GPS-50-2 Menu Options	Page 14
Troubleshooting / Quick tips	Page 18
Service / Warranty	Page 20



## Product Overview

The GPS-50-2 can be used to provide an accurate speedometer signal with a Dakota Digital instrument system as well as many factory and aftermarket speedometers.

- Has built in GPS antenna for compact design.
- When coupled with a Dakota Digital system with a BIM cable, the unit can provide speed, compass, clock, altimeter, and optional air temp functions.
- There are two interface (I/O) ports on the module for use with a Dakota Digital instrument system; either one can be connected to the control box or a BIM-series module, allowing several units to be daisy chained together.
- **The GPS-50-2 cannot be connected to any BIM-01-2 module.**
- Additionally, there are two speedometer outputs for standard speedometers plus a dedicated cruise control speed output.
- The optional SEN-15 outside air temperature sensor can be connected when a Dakota Digital instrument system is connected to provide an outside air temperature reading.
- The optional remote antenna, (mounted on top of the dash), can enhance signal reception if the module is hidden under the dash, and improves cruise control operation.
- Cruise speed output can operate some OEM cruise modules, the CRS-3000 cruise module, and most aftermarket cruise modules.

The GPS speed signal can be momentarily incorrect due to interference from overpasses, tunnels, and nearby structures. To avoid this problem, the system stabilizes the speedometer reading by constantly comparing it with an internal acceleration sensor.

When the key is off, the system goes into a very low power standby mode and only occasionally wakes up to update GPS readings so that it is ready to start operating as soon as the key is turned on.

**If using a BIM-01-2 series with a Dakota Digital dash, the GPS-50-2 must be wired as a standalone, (page 5) without using the BIM cable.**

## Display Legend

The dots in the LED display can tell us if the GPS-50-2 is seeking satellites or has acquired connection.

The upper left dot indicates several operations:

- Slow flashing dot, key off – trying to connect, or stay connected, to satellites.
- Slow flashing dot, key on – trying to connect to satellites.
- Solid dot – contact made. Good if used as a standalone GPS unit without a BIM cable
  - If using a BIM cable to a dash system, no communication with dash, (check BIM cable)
- Steady flashing dot – acquired satellite connection and communicating with dash system with BIM cable

Upper right dot – comes on solid only with key on, indicating at least four satellites are acquired.

Lower right dot – activates when the accelerator takes over when satellite signal is temporarily lost

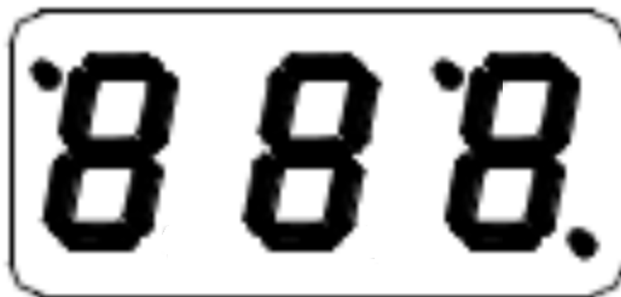

# Installation: Wiring Overview

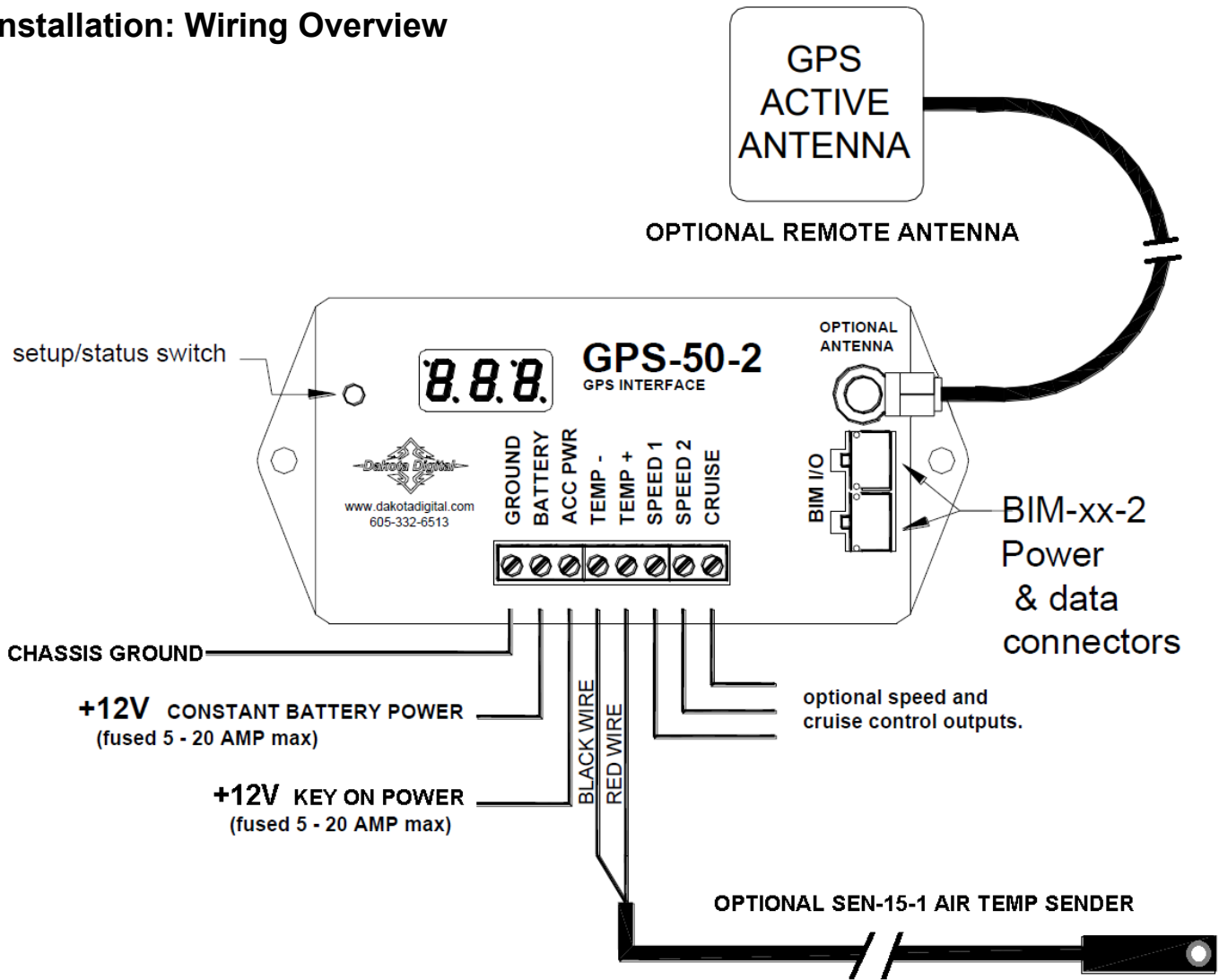

Mount outside air temp sensor behind the grill, in front of radiator. Do not mount where it could be in standing water.

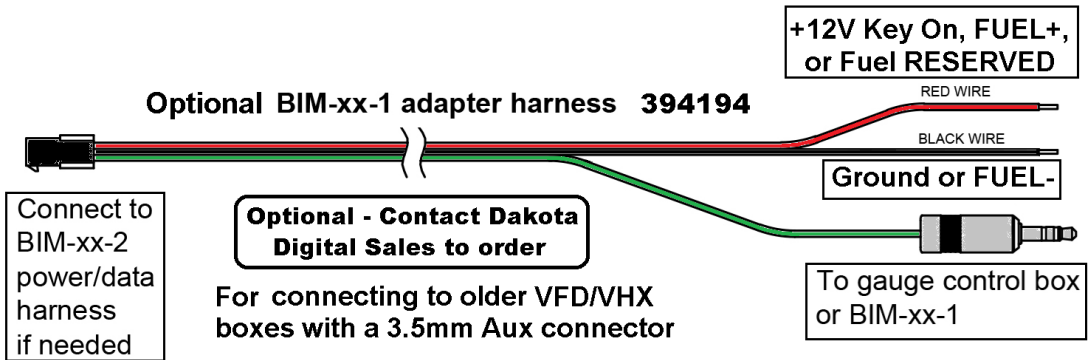
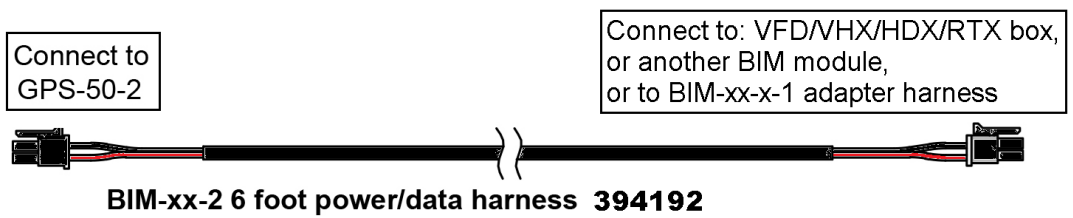

# Installation: Wiring using BIM cable

Using the BIM cable will be the only way for the VFD/VHX/HDX/RTX dash systems to read: Compass, Altimeter, World clock, and Optional outside air temp.

## Connecting GPS-50-2 to VFD / VHX / HDX / RTX with BIM cable

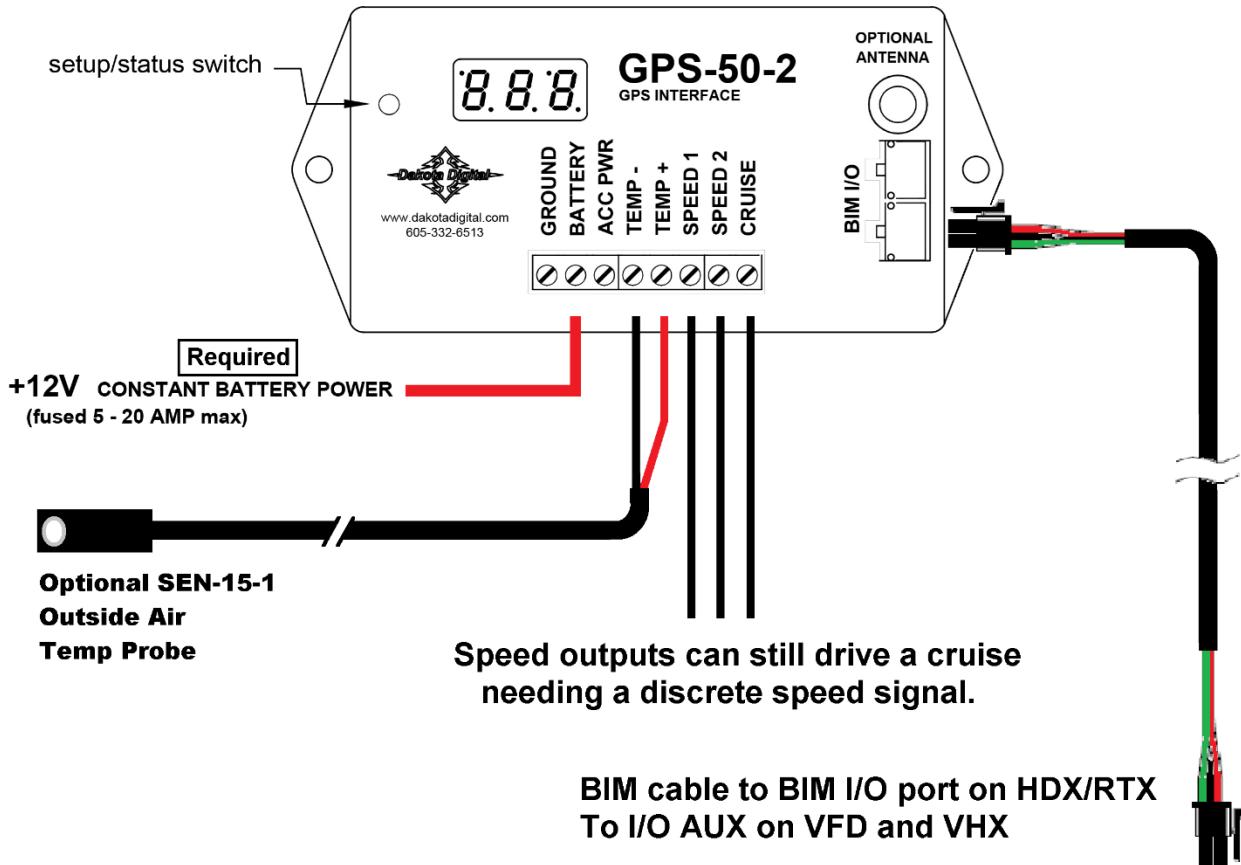

Speed outputs can still drive a cruise needing a discrete speed signal.

BIM cable to BIM I/O port on HDX/RTX  
To I/O AUX on VFD and VHX

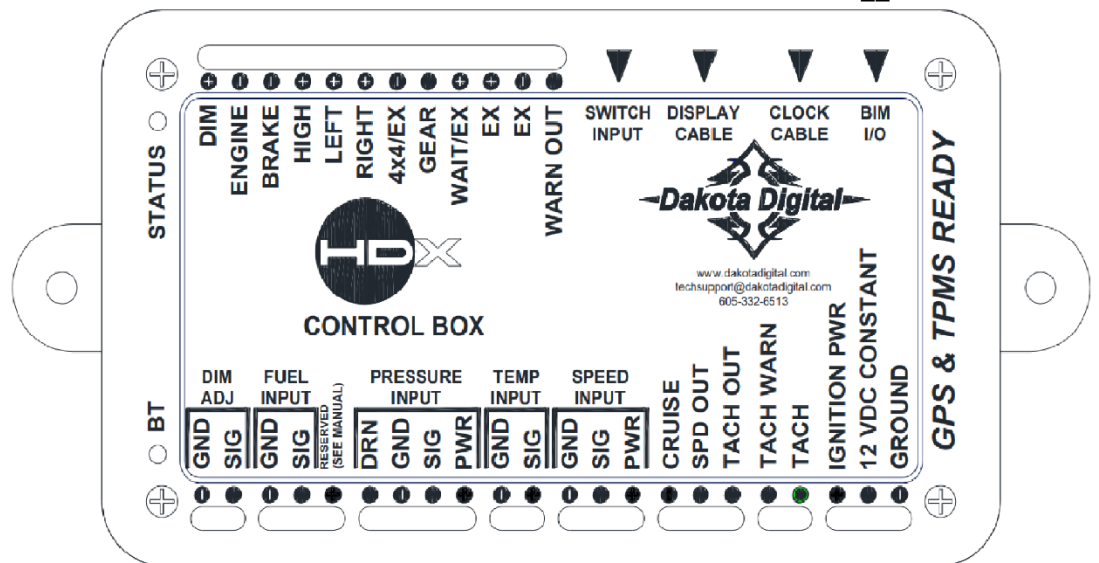

# Installation: Wiring for Standalone Speed\* Using Speed 1 or Speed 2 outputs

## Connecting GPS-50-2 to:

- Standalone speedometer
- Dakota Digital dash system without BIM support
- Dakota Digital dash system while also using a BIM-01-2 series

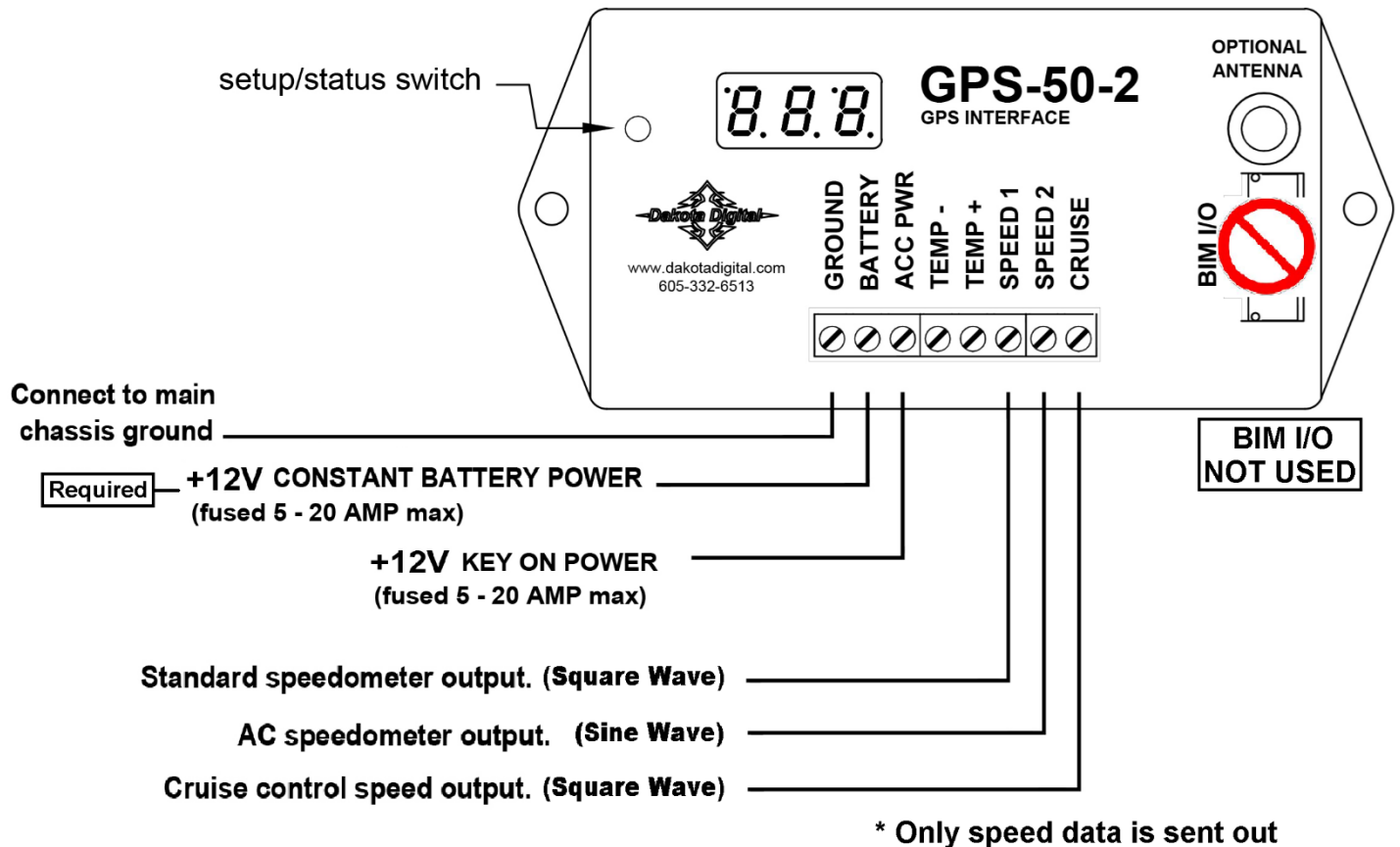

Two speed outputs are offered to accommodate the type of speedometer you have. The speed output frequency is selectable to certain fixed standards, default is 8,000 pulse per mile.

- See page 17 for the speed output options to select from.

All Dakota Digital gauges can use either SPEED 1 or SPEED 2. Other brands of speedometer may only read one or the other.

Those brands that normally ship a three-wire speed sensor, will use SPEED 1.

Those brands the normally ship a two-wire speed sensor, will use SPEED 2.

OEM speedometers tend to use SPEED 1.

OEM GM cruise controls will like the CRUISE signal when the GPS-50-2 output is set to “4”, while the CRS-2000/3000 modules from Dakota Digital need to be configured for the correct pulses, a square wave signal by turning SW 10 on in the cruise module.

- See page 10 for setup options for different gauges

## Installation and Overview

- Do not connect the I/O port to anything other than a Dakota Digital control box or BIM.
- Do not mount the module in the engine compartment; it should be mounted in the vehicle.
- Do not connect into BIM port of any BIM-01-2 series module.
- **Make sure the module is securely mounted and not hanging loose.**
  - The GPS-50-2 uses an internal acceleration sensor which cannot accurately track the vehicle acceleration if the module is not well secured.
- **Optional Antenna** – mount on top of dash, close to window for best reception.
  - Mounting on glass “can” work, but is not the preferred choice
  - *Not designed for exterior use!*

The *5nr* setup menu will aid in selecting an acceptable mounting location. This should be done in a clear, outside area and not inside a building. Hold the switch beside the GPS-50-2 display while turning the key on. The display will show the current revision code while this is held. Release the switch. Press and release the switch until “*5nr*” is displayed. Press and hold the switch until “ - ” is displayed. Press and release the switch until “ *n* ” is displayed. This will show the number of satellites being used. It should be tracking at least 6 satellites. If it is less than this wait a few minutes for it to pick up additional satellites. Press and release the switch until “ *H* ” is displayed. The maximum signal strength will be displayed in real time. You should try different locations to obtain a reading of *40H* or higher. When using the optional antenna move the antenna to different locations to obtain a reading of *40H* or higher.

## Initial setup

Once the module is mounted securely and wired, there are a few internal tasks the GPS module will complete on its own.

First, the module needs time to acquire and track the satellites. This typically won't work inside a steel building, so have the vehicle outside to speed up the process. There is a dot in the upper right of the display that will be on steady or on and flashing any time the key is on. The dot in the top center of the display will be on steady once it has gotten a GPS satellite fix. The unit won't operate until it gets a fix and this may take 1 – 15 minutes depending on various things. This delay is only for the initial GPS fix. After this it will typically begin operating within a few seconds of turning the key on.

The second step is to let the internal acceleration sensor learn how it is mounted in the vehicle. You can mount it securely in any position you want. When you are sitting still it learns which way is up. In order to learn which way is the front of the vehicle you need to accelerate or decelerate on a straight stretch of road. Accelerate or decelerate for at least 2.5 seconds and make sure your speed changes by at least 10 mph. This procedure only needs to be done initially and doesn't need to be repeated unless you move the module to a different mounting location.

If you move it to a new mounting location or a different vehicle, enter the setup menu and select the *r5t* option to speed up learning the new mounting position.

## Dakota Digital display data usage

The speed outputs can each be used in place of a separate transmission connection to the gauge control unit. The clock is based on the accurate GPS time and only the hours need to be set to match it to your time zone. The compass requires no setup or calibration for the vehicle and is accurate any time the vehicle is moving. The altimeter is calculated from the GPS position data to give your current elevation. Each of these will be displayed in the message center and can be individually turned on or off.

## Setup Using BIM cable to VFD/VHX/HDX/RTX:

Cannot be connected to BIM-01-2 series

**GPS-50-2 BIM speed MUST be enabled. See page 15 for details.**

## Setup VFD3 / VFD3X

### Using speed from the GPS-50-2 without a BIM-01-x connected

- Connect the GPS-50-2 to the instrument system control box with the supplied BIM power/data cable(s).
- Hold SW1 (I) for the VFD3 control box, and turn key on.
  - Speed will display **SEt** and the message display will show **SETUP**.
- Release SW1. The speed will display **SEt** and the message center will display **SPEED**.
- Press and hold SW1 (I) until “ – ” and **SPEED** are displayed.
- Release SW1. Speed will display **SEt** and the message center will display **SENDER**.
- Press and hold SW1 (I) until “ – ” and **SENDER** are displayed.
- Release SW1 (I). Speed will display **SEt** and the message center will display current setting
  - Default setting is **NORMAL**
- Tap SW1 (I) until **SEt** and **BUS** are displayed
- Press and hold SW1 (I) until speed displays “ – ”, and message center displays **DONE**
- Release SW1 (I). Speed will display **SEt** and the message center will display **ADJUST**
- Tap SW1 until **SEt** and **DONE** are displayed.
- Press and hold SW1 (I) until speed displays “ – ” and the message center displays **DONE**
- You may turn off the key now.

## Setting the World Clock Time Zone Hours

- The time from the GPS is setup through the VFD3 BIM setup.
- Hold SW1 (I) for the VFD3 control box, and turn key on.
  - Speed will display **SEt** and the message display will show **SETUP**.
- Release SW1. Speed will display **SEt** and the message center will display **SPEED**.
- Tap SW1 (I) until **SEt** and **BIM** are displayed.
- Press and hold SW1 (I) until “ – ” and **SCAN X** is displayed.
  - X = the number channels. Default is “3”, (Clock, Compass, Altimeter).
- Release SW1 (I). **SEt** and **SCAN** will be displayed.
- Tap SW1 (I) once for **SEt** and **SETUP** to be displayed.
- Press and hold SW1 (I) until “ – ” and **SETUP** are displayed.
- Release SW1 (I). Speed will display “[ 7” and the message center will display **CLOCK**.
  - [ 7 represents the clock is using ID channel 7.
- Press and hold SW1 (I) until “ – ” and **LABEL** are displayed.
- Release SW1 (I). **SEt** and **CLOCK** are displayed.
  - The label for the clock is “**CLOCK**”, and cannot be changed.
- Hold SW1 (I) until “ – ” and **CLOCK** is displayed.
  - If the system has a second message center, it will also display **CLOCK**.
- Release SW1 (I), **SEt** and the hours will display in the message center.
- Tap SW1 (I) to change the hours in the message center.
  - GPS minutes are atomically accurate, only the hours are changed for the time zone
- Press and hold SW1 (I) to save hours, until “ – ” and the hours are displayed
- Release SW1 (I). **SEt** and **DONE** are displayed.
- Press and hold SW1 (I) until “ – ” and **DONE** are displayed.
- Release SW1 (I). The speed will show the software version and message will display **INFO**.
- You may turn off the key now.

## Setup VHX

### Using speed from the GPS-50-2 without a BIM-01-x connected

**GPS-50-2 BIM speed MUST be enabled. See page 15 for details.**

- Connect the GPS-50-2 to the instrument system control box with the supplied BIM power/data cable(s).
- Hold SW1 (I) for the VHX control box, and turn key on.
  - The VHX LCD display should show **SETUP SPEED**.
- Release SW1. The message display should show **SPEED**.
- Press and hold SW1 (I) until the LCD will display **SPEED SENDER**
- Release SW1 (I), the LCD will still display **SPEED SENDER**
- Press and hold SW1 (I) until only **SENDER** is displayed.
- Release SW1 (I). The display will read **SENDER** and the sender type.
  - The default reading is **SENDER NORMAL**
- Tap SW1 (I) until **SENDER BUS** is displayed.
- Press and hold SW1 until a large **DONE** is displayed
- Release SW1 (I), and the LCD should display **SPEED ADJUST**.
- Tap SW1 (I) until **SPEED DONE** is displayed.
- Press and hold SW1 (I) until a large **DONE** is displayed.
- You may turn the key off now.

### Setting the World Clock Time Zone Hours

- The time from the GPS clock is setup through the VHX BIM setup.
- The VHX clock is still done at the clock screen on the display, and not in setup.
- Hold SW1 (I) for the VHX control box, and turn key on.
  - The VHX LCD display should show **SETUP SPEED**.
- Release SW1 (I). The message display should show **SPEED**.
- Press and release SW1 until **SETUP BIM** is displayed.
- Press and hold SW1 (I). The LCD will display **SCANNING** with **CH** and counting numbers.
- Release SW1 when the LCD displays **FOUND XX** and **XX ERRORS**.
  - The XX represent the number of channels found or that have conflicts
  - With only the GPS-50-2 the LCD should display **FOUND 03** and **00 ERRORS**
  - If the display reads **FOUND 00**, check connections and constant power to GPS-50-2
- Tap SW1 (I) to display **BUS SCAN**.
- Tap SW1 (I) once to display **BUS SETUP**.
- Press and hold SW1 (I), until the message changes.
  - If only using the GPS-50-2 it will read **BIM CH 07** and **CLOCK**.
  - If another BIM is in the chain and uses a lower channel, tap SW1 (I) to display **BIM CH 07**
- Press and hold SW1 (I) until the LCD displays **CH 07 CLOCK LABEL**.
- Release SW1 (I) and the LCD will continue to display **CH 07 CLOCK LABEL**.
- Press and hold SW1 (I) until the LCD displays **BIM CLOCK** and **00:XX**
  - The XX represents the GPS minutes – the highlighted hours may be different.
- Tap SW1 (I) to change the hours to match your current (or any) time zone.
- Press and hold SW1 (I) the screen may flash.
- Release SW1 (I) when **SET AS MAIN CLOCK?**  is displayed.
  - This option could replace the onboard clock with the GPS clock.
  - If saved as "No"  the VHX will display two different clocks in the LCD.
- **It is up to you if you want two clocks with two different times, or one clock.**
- Tap SW1 (I) once to change the  to a  making the main clock the GPS clock.
- Press and hold SW1 (I) if either option is chosen.
- Release SW1 (I) when the LCD displays **BIM CH 08 COMPASS**
- Tap SW1 (I) until the LCD displays **BIM SETUP DONE**
- Press and hold SW1 (I) until the LCD displays a large **DONE**
- Release SW1 (I). **BIM DONE** will be displayed.
- Press and hold SW1 (I) until the LCD displays a large **DONE**
- Release SW1 (I)
- You may turn the key off now.

## Setup HDX/RTX

### Using speed from the GPS-50-2 without a BIM-01-x connected

**GPS-50-2 BIM speed MUST be enabled. See page 15 for details.**

**\*\*HDX/RTX systems can be configured with the Dakota Digital app for Apple and Android devices\*\***

- Connect the GPS-50-2 to the instrument system control box with the supplied BIM power/data cables.
- Enter setup:
  - HDX – Key on – Press and hold both switches on speed display.
    - The LCD will show “ENTER SETUP” with a scrolling bar.
    - Once “SETUP” “RELEASE” is shown, release both switches.
  - RTX – Hold SW2 (II) and turn on key on.
    - System will say “SETUP” – release the switch to show the menu
- Tap the right switch, or SW2 (II), until “SPEED” is highlighted in the center.
- Hold either switch to enter submenu. Release when instructed.
- Tap switch until “INPUT” is highlighted, then hold switch. Release when instructed.
- “SIGNAL” is highlighted, hold switch. Release when instructed.
- Tap switch until “BIM” is highlighted
- Press and hold switch to save. Release when instructed.
- Tap switch until “BACK” is shown, then hold switch. Release when instructed.
- Tap to “BACK” and hold the switch. Release when instructed.
- Tap until “EXIT SETUP is highlighted, then hold the switch. Release when instructed.
- This will make the final save, and exit the setup menu, returning to normal operation.
- You may turn the key off.

## Setting the clock hours

- The GPS-based time is automatically used by the HDX/RTX system and can be adjusted through the HDX/RTX programming switches.
- You can change the hours (time zone) by following the steps below.
- **NOTE: Adjusting the minutes will override the GPS-based time.**
- Turn the key on.
- Tap the left switch (or SW1) until the focus arrow is beside the clock.
  - If the clock is not displayed, tap the right switch until the home screen is displayed with clock.
  - HDX: 62T-FJ, 65F-MUS, 67F-PU. RTX : 47C-PU and 57C. – Clock must be set in a group screen.
  - Once the clock is in a group screen follow the same process of accessing.
- Hold either switch to enter clock setup.
- The display will show “HOLD TO SET”. Release when instructed.
- The hours will begin flashing. Tap the right switch to increase the hours, tap the left switch to decrease.
- Press and hold either switch to save the hours. The minutes will flash.
- Press and hold either switch to skip past minutes.
  - **Minutes could be changed, BUT: adjusting the minutes will override the GPS-based time.**
  - Tap the right switch to increase the minutes, tap the left switch to decrease the minutes.
- Press and hold either switch to return to normal operation.

## Setup for Standalone Speed

### Using Speed 1 or Speed 2 wire to control box or gauge:

- When using a standalone speedometer.
- When a system control box is connected to BIM-01-2 series.
- When using an early control box with no BIM support.

The speedometer's signal input should be connected to either SPEED 1 or SPEED 2 depending on the speedometer requirements.

SPEED 1 is a square wave signal for some OEM and aftermarket speedometers.

SPEED 2 is a sine wave signal for most older speedometers.

Dakota Digital speedometers, and dash systems, can use either output.

CRUISE is a square wave output for most cruise controls.

If you are unsure of which to use, start with SPEED 1 and then switch to SPEED 2 if 1 doesn't work.

You can also test the speedometer connection by entering the Speedometer Output Setup / Test described on page 16.

When the correct signal is obtained, most speedometers should read 60 mph.

All three outputs generate the same speed frequency.

---

Connecting to stand alone speedometer

Dakota Digital ODY or ODYR/SLX speedometer = Gray VSS wire

Connect either SPEED 1 or SPEED 2 to the speed input to the control box

Early VFD3 or STR control box = SPEED terminal

VFD3/VHX = SPD SND terminal

HDX/RTX = "Speed Input" SIG terminal

Normally no changes are required to the system control box.

Default settings on all control boxes with a "I/O AUX" or "BIM I/O" input are:

VFD3/VHX = **SPEED SENDER = NORMAL**

HDX/RTX = **SPEED > INPUT > SIGNAL = SENSOR**

You may refer to the previous setup screens, to verify settings.

However, **do not** change the setting to **BUS** or **BIM**.

## Speed Calibrations:

**The following speed calibrations can be done without the need to drive the car.**

ODY, ODYR/SLX, STR and early metal box VFD3 systems are defaulted to read 8,000 pulses per mile.  
VHX/HDX/RTX and black plastic cased VFD3 system are defaulted to 16,000 pulse per mile.

Follow the Speedometer Output/Test setup on the next pages to generate a 60 MPH speed signal

For 8,000 PPM devices set the output to **8** (\*default)

For 16,000 PPM devices, set the output to **16**.

To eliminate the "**PLEASE SET SPEED**" messages, the speed calibration can usually be done with the adjust mode without even driving the car.

When the GPS-50-2 is sending out the correct test signal, the speedometer should be reading 60 MPH (96 km/h) or be adjusted to 60 MPH (96 km/h).

## Speed Calibration using the Adjust mode VFD3 / VHX / HDX / RTX:

This method requires entering setup of the GPS-50-2 AND the VFD/VHX/RTX at the same time.

- HDX setup can occur after the ignition is turned on.

**\*\*HDX/RTX systems can be configured with the Dakota Digital app for Apple and Android devices\*\***

### Enter Setup of GPS and VFD3/VHX/HDX/RTX

- Hold the switch beside the GPS-50-2 display and SW1 for VFD3/VHX/RTX
- Turning the key on. Release both switches.
  - HDX can enter setup after the ignition is on.
- The GPS display will show the current revision code while this is held.
- Release the switch. The display will show “-[-”.
- Tap the switch once, until “SPd” is displayed.
- Press the switch and hold the switch until “ - ” is displayed.
- Release the switch. The display will show the current speed pulse setting:
  - 4 = 4,000
  - 8 = 8,000 (default)
  - 16 = 16,000
  - 54 = 54,400
  - 128 = 128,000
- Tap the switch on the GPS-50-2 to change the speed output
  - Expected default speed inputs to display 60 MPH (96 km/h):
    - Current (plastic case) control boxes = 16,000 PPM - 16
    - Aluminum VFD3, and STR boxes = 8,000 PPM - 8
- 

**Once the GPS-50-2 is set to the correct pulse rate, follow the speed setup in the appropriate system manual(s) for the Adjust Mode, or use the app for HDX and RTX.**

- Sometimes the speed may not read 60 MPH (96 km/h), adjust so they match.
- Sometimes the speed may match, but it is okay to offset the speed by 1 MPH or km/h

### Saving Setting in VFD3 / VHX / HDX / RTX

- **VFD3 (old and current Series III) and VHX**
  - Manuals say to come to stop, since the car is not moving, simply save the GPS settings
  - Press and hold the GPS switch to save the setting.
  - Tap the GPS-50-2 switch to display **End**, then hold to exit.
  - Once the speedometer is reading zero, you may turn the ignition off.
- **HDX and RTX**
  - The corrected speed must be maintained for at least a full 10 seconds.
  - After a full 10 seconds, press and hold the GPS switch to save the setting.
  - Tap the GPS-50-2 switch to display **End**, then hold to exit.
  - You may turn the key off.

## Speed Calibration using the Adjust mode STR-D (Series II):

- Enter GPS setup as explained on the previous page.
- Set Speed Output / Test mode to 8,000 PPM - **B**
- Then press and hold BOTH Trip and Reset switches for about 10 seconds on the STR-D
- **Follow STR-D instructions on adjusting to 60 MPH (96 km/h) and saving.**
  - Sometimes the speed may not read 60 MPH (96 km/h), adjust so they match.
  - Sometimes the speed may match, but it is okay to offset the speed by 1 MPH or km/h
- Save and exit GPS-50-2 Speed Output / Test
  - Press and hold the GPS switch to save the setting.
  - Tap the GPS-50-2 switch to display **End**, then hold to exit.
- Once the speedometer is reading zero, you may turn the ignition off.

## Speed Calibration using the Adjust mode ODY, ODYR, SLX:

- Enter GPS setup AND speedometer, as explained on the previous page.
- Set Speed Output / Test mode to 8,000 PPM - **B**
- **Once the GPS-50-2 is set to the correct pulse rate, follow the speed setup in the appropriate speedometer manual for the Adjust Mode.**
  - Sometimes the speed may not read 60 MPH (96 km/h), adjust so they match.
  - Sometimes the speed may match, but it is okay to offset the speed by 1 MPH or km/h
- The corrected speed must be maintained for at least a full 10 seconds.
- After a full 10 seconds, press and hold the GPS switch to save the setting.
- Save and exit GPS-50-2 Speed Output / Test
  - Press and hold the GPS switch to save the setting.
  - Tap the GPS-50-2 switch to display **End**, then hold to exit.
- Once the speedometer is reading zero, you may turn the ignition off.

## Speed Calibration with STR-A/B/C models:

- Enter GPS setup as explained on the previous page.
- Set Speed Output / Test mode to 8,000 PPM - **B**
- Gently adjust the SPEED ADJ pot with a small screwdriver until the speed reads 60 MPH
  - Or 96 KM/H
- Save and exit GPS-50-2 Speed Output / Test
  - Press and hold the GPS switch to save the setting.
  - Tap the GPS-50-2 switch to display **End**, then hold to exit.
- Once the speedometer is reading zero, you may turn the ignition off.

## Cruise control operation with the GPS-50-2

While a transmission or wheel based speed signal is ideal for operating a cruise control, the GPS-50-2 can be used when this is not available.

If the optional remote antenna is not used, special care must be taken in selecting the mounting location for the GPS-50-2 so that it can get a clear view of the satellites.

- The difference in mounting locations is not noticeable for a speedometer, but can affect the precision operation of a cruise control system.
- Try to locate the GPS-50-2 as high, and close to the glass, as possible.
  - It can be under a fiberglass or wood dash or in a headliner (fiberglass body).
  - An unused metal speaker grill can be replaced with wood or plexiglass and the GPS-50-2 can be mounted beneath the nonmetallic material
- Avoid having the unit surrounded by steel.

We prefer use of the optional Remote GPS antenna. This can connect to the OPTIONAL ANTENNA connector on the GPS-50-2 and be used instead of the internal antenna.

The small, external antenna can then be mounted on top of the dash, to get a clear view of the satellites, while the GPS-50-2 can remain hidden under the dash.

- The GPS-50-2 CRUISE terminal provides an ECM style speed output signal for use with cruise control systems.
  - The output frequency for the CRUISE terminal is the same as for the SPEED terminals.
  - The default output of the GPS-50-2 is 8,000 pulses per mile.
  - 4,000 pulse per mile (square wave) is a common speed used in OEM GM cruises.

**NOTE:** It is not uncommon for the raw GPS speed data to vary by as much as 6 MPH when going under a large bridge or other (metallic) structure. The brief change of signal is usually not seen on a speedometer, however that could fool the sensitive cruise into thinking the speed changed. It may be possible to feel the cruise make a slight adjustment, even though your speedometer will not show a change.

## GPS-50-2 Setup

### GPS menu table:

Menu	Sub-Menu	Options	Default	Notes
-[-				Set BIM ID's
	SPd	On OFF	On	Enable or disable speed data on BIM
	CL	1-16,OFF 12H - 24H	7 12H	Set clock ID Setting clock format to 12 hours or 24 hours
	CPS	1-16,OFF	8	Set compass ID
	ALt	1-16,OFF	16	Set altimeter ID
	End			Exit
SPd		4,8, 16,54, 128	8	Set, or test, the speedometer output calibration: 4=4K, 8=8K, 16=16K, 54=54.4K, 128=128K ppm All speed outputs send the same frequency.
CARL				GPS/accelerometer override settings
	Lo	0-130	70	Lowest speed accelerometer override is allowed, default setting should be used
	AD1	0.3-1.6,OFF	.8	GPS > accel, default setting should be used
	AD2	0.3-1.6,OFF	OFF	Accel > GPS, default setting should be used
	UPd	F5t,5L0	F5t	Speed averaging update, default setting should be used
r5t				Reset module orientation (relearn which direction is up and forward)
5nr				Signal to noise ratio readings for trouble shooting and diagnostics
	xxH			Highest signal reading
	xxL			Lowest signal reading
	xx-			Average signal reading
	xxn			Number of satellites being used
End				Exit Setup.

## Configuration Setup : -[-

### Setup: Enable Speed on BIM output - 5Pd

- Hold the switch beside the GPS-50-2 display while turning the key on.
- The display will show the current revision code as long the switch is held.
- Release the switch. The display will show “-[-”.
- Press and hold the switch until “ - ” is displayed.
- Release the switch. The GPS-50-2 display will show “5Pd”.
- Press and hold the switch until “ - ” is displayed.
- Release the switch. The display will show the current speed setting.
  - The default should be “0n”
- If the setting is showing “OFF”, tap the switch once to display “0n”
- Press and hold the switch until “ - “ is displayed.
- Release the switch. The GPS-50-2 display will show “[-L”.
- Tap the switch until “End” is displayed
- Press and hold the switch until “ - “ is displayed.
- Release the switch. The GPS-50-2 display will show “5Pd”.
- Tap the switch until “End” is displayed.
- Press and hold the switch until “ - “ is displayed.
- Release the switch. The GPS-50-2 display will show “Int”, or “E-R” and then blank out.

### ID Number setups

Most (not all) BIM modules use a channel ID between 1 and 16 to transmit specific data to a dash control box. Having multiple BIMs like the GPS-50-2 and BIM-19-2 (air pressure) could have a conflict with the Altimeter and Tank pressure, as they both use channel 16. Changing the GPS-50-2 Altimeter ID to 9 or 10 will avoid any conflicts with the five pressure channels in the BIM-19-2.

### Setup: GPS clock ID number and time format - [-L

- Hold the switch on the GPS-50-2 module while turning the key on.
- The display will show the current revision code as long the switch is held.
- Release the switch. The display will show “-[-”.
- Press and hold the switch until “ - ” is displayed.
- Release the switch. The BIM display will show “5Pd”.
- Tap the switch until “[-L” is displayed.
- Press and hold the switch until “ - ” is displayed.
- Release the switch. The display will show the current ID for the GPS clock.
- Tap the switch to change the setting from 1-16 or “OFF”
  - Default is “7”
  - “OFF” will prevent the GPS clock from being displayed.
- Press and hold the switch to save the setting. The GPS-50-2 display will show “12H” or “24H”.
- Release the switch. This is the current time format.
- Tap the switch to change between 12 hour and 24 hour format.
- Press and hold the switch until “ - “ is displayed.
- Release the switch. The GPS-50-2 display will show “[-P5”.
- Tap the switch until “END” is displayed
- Press and hold the switch until “ - “ is displayed.
- Release the switch. The GPS-50-2 display will show “5Pd”.
- Tap the switch until “END” is displayed.
- Press and hold the switch until “ - “ is displayed.
- Release the switch. The GPS-50-2 display will show “Int”, or “E-R” and then blank out.

## Configuration Setup Continued : -[-

### Setup: Compass ID number - [P5

- World Cock shares with Compass data on Compass ID
  - Turning off the Compass ID will also turn off the clock
- Hold the switch beside the GPS-50-2 display while turning the key on.
- The display will show the current revision code as long the switch is held.
- Release the switch. The display will show “-[-”.
- Press and hold the switch until “ - ” is displayed.
- Release the switch. The GPS-50-2 display will show “SPd”.
- Tap the switch until “[P5” is displayed.
- Press and hold the switch until “ - ” is displayed.
- Release the switch. The display will show the current ID for that reading.
  - Default is “B”
- Tap the switch to change the setting from I- I6 or “OFF”.
  - “OFF” will prevent it from being displayed.
- Press and hold the switch until “ - ” is displayed.
- Release the switch. The GPS-50-2 display will show “ALt”.
- Tap the switch until “End” is displayed
- Press and hold the switch until “ - ” is displayed.
- Release the switch. The GPS-50-2 display will show “SPd”.
- Tap the switch until “End” is displayed.
- Press and hold the switch until “ - ” is displayed.
- Release the switch. The GPS-50-2 display will show “ InL”, or “E-R” and then blank out.

### Setup: Altimeter ID number - ALt

- Hold the switch beside the GPS-50-2 display while turning the key on.
- The display will show the current revision code as long the switch is held.
- Release the switch. The display will show “-[-”.
- Press and hold the switch until “ - ” is displayed.
- Release the switch. The GPS-50-2 display will show “SPd”.
- Tap the switch until “ALt” for altimeter.
- Press and hold the switch until “ - ” is displayed.
- Release the switch. The display will show the current ID for that reading.
  - Default is “ I6”
- Tap the switch to change the setting from I- I6 or “OFF”.
  - “OFF” will prevent it from being displayed.
- Press and hold the switch until “ - ” is displayed.
- Release the switch. The GPS-50-2 display will show “End”.
- Press and hold the switch until “ - ” is displayed.
- Release the switch. The GPS-50-2 display will show “SPd”.
- Tap the switch until “End” is displayed.
- Press and hold the switch until “ - ” is displayed.
- Release the switch. The GPS-50-2 display will show “ InL”, or “E-R” and then blank out.

## Speedometer output setup / test : *5Pd*

- The speed output is a test function to see if the speed outputs (not through the BIM cable) can drive an ECU / speedometer at a certain Pulse Per Mile rate.
- **These values cannot be fine-tuned and represent commonly seen vehicle speed signals.**
- When the correct signal is obtained, most speedometers should read 60 mph.
- This can also be used to adjust speed calibration in a Dakota Digital speedometer.
  - Both speedometer and GPS must go into setup at the same time.
- This adjustment affects ALL three speed outputs
  
- Hold the switch beside the GPS-50-2 display while turning the key on. The display will show the current revision code while this is held.
- Release the switch. The display will show “-[-”.
- Tap the switch once, until “*5Pd*” is displayed.
- Press the switch and hold the switch until “ - ” is displayed.
- Release the switch. The display will show the current speed pulse setting:
  - *4* for 4000
  - *8* for 8000 \*default
  - *16* for 16000
  - *54* for 54400
  - *128* for 128000
- Tap the switch to change the setting.
- Press and hold the switch until “ - ” is displayed.
- Release the switch. The GPS-50-2 display will show “*End*”.
- Press and hold the switch until “ - ” is displayed.
- Release the switch. The GPS-50-2 display will show “*CAL*”.
- Tap the switch until “*End*” is displayed.
- Press and hold the switch until “ - ” is displayed.
- Release the switch. The GPS-50-2 display will show “ *Int*”, or “*E-R*” and then blank out.

## Calibration / Override settings : *CAL*

The section list as *CAL* is to alter the accelerometer settings. These should be left at the default settings unless specifically told by a technician to make adjustments.

## Reset - *r5t*

- This will reset the accelerometer and any changes made in the *CAL* section.
- Resetting is useful if the GPS-50-2 was relocated or accidentally moved.
- If the GPS is not sending speed, but the speedometer may jump to 60 at key on or start, then follow these steps.
  
- Remove the battery wire for a few seconds
- Reconnect battery wire
- Hold the switch on the GPS-50-2 module while turning the key on.
- The display will show the current revision code as long the switch is held.
- Release the switch. The display will show “-[-”.
- Tap the switch until “*r5t*” is displayed, release the switch
- Press and hold the switch until “*r5t*” changes to a “ - “, release the switch.
- Tap the switch until “*End*” is display.
- Press and hold the switch, until a “ - ” is displayed, release the switch to restart the GPS.

## Troubleshooting quick tips

While the GPS-50-2 is operating, the dot in the upper left corner of the display will indicate the status. On steady indicates it is powered up but not receiving any BIM bus activity. Flashing indicates it is communicating on the BIM bus. A dot in the upper center indicates that it is receiving a valid GPS signal. A dot in the lower center indicates the accelerometer is actively correcting the speedometer reading.

When the key is off the dot in the upper left corner will flash very slowly. If the switch on the GPS-50-2 is held, it will flash rapidly indicating that the key is off.

To see the number of satellites being tracked, signal strength, speed, and heading on the GPS display, press and hold the switch with the key on. It will toggle between displaying the number of satellites tracked followed by a dash ( *SD-* ), the signal strength followed by three dashes, current speed in km/h, and the heading in degrees.

## Troubleshooting guide

<b>Problem</b>	<b>Possible cause</b>	<b>Solution</b>
GPS will not light up (using BIM cable)	<ul style="list-style-type: none"> <li>- Missing Constant Power</li> <li>- BIM cable not connected</li> <li>- Damaged BIM cable</li>   <li>- Verify no other BIM is problem</li> <li>- Unit damaged</li> </ul>	<ul style="list-style-type: none"> <li>- Connect battery power to BATTERY</li> <li>- Connect BIM cable</li> <li>- Inspect for damage / connect ACC PWR and GROUND terminals to car / verify VFD3/VHX/HDX/RTX system is lighting</li> <li>- Connect direct to system box</li> <li>- Contact for service</li> </ul>
GPS will not light up (standalone)	<ul style="list-style-type: none"> <li>- Missing constant power</li> <li>- Missing ground</li> <li>- Missing or low ignition power</li> </ul>	<ul style="list-style-type: none"> <li>- Connect battery power to BATTERY</li> <li>- Connect ground wire to GROUND</li> <li>- Connect accessory or ignition power from fuse panel to ACC PWR.</li> <li>- Verify key on power is above 10 volts</li> </ul>
GPS has steady dot in left corner (using BIM cable)	<ul style="list-style-type: none"> <li>- BIM cable loose or damaged</li> </ul>	<ul style="list-style-type: none"> <li>- Reseat BIM cable / check for continuity on green wire / remove other BIM units</li> </ul>
GPS is flashing <i>CL</i> , <i>CP5</i> or <i>RLT</i>	<ul style="list-style-type: none"> <li>- ID conflict with another BIM</li> </ul>	<ul style="list-style-type: none"> <li>- Change ID on GPS or BIM to avoid conflict of the listed conflict</li> </ul>
GPS is flashing <i>SPd</i> & no speed out	<ul style="list-style-type: none"> <li>- GPS speed is conflicting with a BIM-01-2</li> </ul>	<ul style="list-style-type: none"> <li>- As long as the BIM-01-2 can send speed do not connect the GPS to the BIM</li> </ul>
Data not coming through to system, Speed, Clock, Compass or Altimeter	<ul style="list-style-type: none"> <li>- Missing battery power or BIM cable not connected</li> <li>- Conflict with an ID channel</li> <li>- Not using BIM cable</li> </ul>	<ul style="list-style-type: none"> <li>- Connect constant power to BATTERY, connect BIM cable</li> <li>- Change ID channel on GPS or BIM</li> <li>- Without BIM cable additional data is not sent</li> </ul>
Speed reads 0, slow flashing left LED dot, no right dot	<ul style="list-style-type: none"> <li>- No GPS data received</li>   <li>- No satellite connection</li> </ul>	<ul style="list-style-type: none"> <li>- GPS may still be trying to acquire satellite contact, may take 5-15 min.</li> <li>- Metal structure may be blocking signals, move vehicle outside</li> </ul>
Speed reads 0, speed might jump to 60 with key on - left LED dot may be on solid or steady flashing, lower right LED dot may be on	<ul style="list-style-type: none"> <li>- GPS was moved on purpose or by accident</li> </ul>	<ul style="list-style-type: none"> <li>- Follow reset procedure on page 17</li> </ul>
Speed reading is incorrect (BIM cable)	<ul style="list-style-type: none"> <li>- Adjust percentage is offset</li> </ul>	<ul style="list-style-type: none"> <li>- Correct adjustment is dash system setup</li> </ul>
Speed reading is incorrect (standalone)	<ul style="list-style-type: none"> <li>- Incorrect output set</li>   <li>- Speedometer not calibrated</li>   <li>- Speedometer requires a fixed input and cannot be calibrated</li> </ul>	<ul style="list-style-type: none"> <li>- Set GPS output to match speedometer expected pulses per mile</li> <li>- Follow aftermarket speedometer instructions on calibration</li> <li>- With OEM speedometers, the output of the GPS-50-2 may have to be fine-tuned with the SGI-100BT</li> </ul>

## Troubleshooting guide, continued

Problem	Possible cause	Solution
Speed really lags or is erratic	<ul style="list-style-type: none"> <li>- GPS is not secured and may be jostled while driving</li> <li>- Internal accelerometer may not be fully programmed</li> </ul>	<ul style="list-style-type: none"> <li>- Make sure GPS is secured</li> <li>- Perform a reset, then drive in a straight line, accelerating and braking several times to train accelerometer</li> </ul>
Cruise control will not engage	<ul style="list-style-type: none"> <li>- Speed pulses do not match</li> <li>- Cruise set to wrong waveform</li> <li>- Loose wire</li> </ul>	<ul style="list-style-type: none"> <li>- Configure GPS speed output to match cruise, (CRS-3000 can also be changed)</li> <li>- Set CRS to Square Wave, 10 ON</li> <li>- Check all connections, avoid crimp connectors</li> </ul>
Cruise will not hold steady speed	<ul style="list-style-type: none"> <li>- Speed output not matching</li> <li>- CRS control gain set high</li> <li>- Slack in linkage or unsecure cable from cruise module</li> <li>- GPS not getting clear signal</li> <li>- Speed wire picking up interference</li> </ul>	<ul style="list-style-type: none"> <li>- Change speed output of GPs-50-2 to match cruise, and/or adjust CRS pulses to match GPS-50-2</li> <li>- Set gain to lowest setting</li> <li>- Follow the CRS-3000 manual for cable slack and mounting procedures.</li> <li>- Relocate GPS-50-2 away from metal that may interfere with reception</li> <li>&gt; Purchase external antenna 600041 and mount on dash for clear reception</li> <li>- Move any tach leads away from speed wire from the GPS-50-2 to cruise</li> </ul>

<b>GPS-50-2 Specifications</b>	
SUPPLY VOLTAGE	
Battery Power	6 to 22 V
Accessory Power	6 to 22 V
SPEED OUTPUTS	
Update Rate	10 Hz
SPEED 1	Ground switching (1.4 A max)
SPEED 2	+/- 6V typical at 13V power
CRUISE	Ground switching (0.3 A max)
CURRENT DRAW	
Accessory On	≈ 39 mA
Accessory Off	≈ 4 mA

## **SERVICE AND REPAIR**

DAKOTA DIGITAL offers complete service and repair of its product line. In addition, technical support is available to help you work through any questions or problems you may be having installing one of our products. Please read through the Troubleshooting Guide. There, you will find the solution to most problems.

For additional support, please visit [www.dakotadigital.com](http://www.dakotadigital.com). A "Product Support" link will be found at the bottom of the home page.

**Should you ever need to send the unit back for repairs, please call our technical support line, (605) 332-6513, to request a Return Merchandise Authorization number.**

- Package the product in a good quality box along with plenty of packing material.
- Ship the product by a common carrier with tracking abilities.
- Be sure to include the RMA number on the package.
- Include a complete description of the problem, with RMA number, your full name and address (street address preferred), and a telephone number where you can be reached during the day.
- Any returns for warranty work must include a copy of the dated sales receipt from your place of purchase.

Send no money. We will contact you for payment.

### **Dakota Digital Limited Lifetime Warranty**

DAKOTA DIGITAL warrants to the ORIGINAL PURCHASER of this product that should it, under normal use and condition, be proven defective in material or workmanship for the lifetime of the original vehicle it was installed in, such defect(s) will be repaired or replaced at Dakota Digital's option.

This warranty does not cover nor extend to damage to the vehicle's systems, and does not cover diagnosis, removal or reinstallation of the product. This Warranty does not apply to any product or part thereof which in the opinion of the Company has been damaged through alteration, improper installation, mishandling, misuse, neglect, or accident. Dakota Digital assumes no responsibility for loss of time, vehicle use, owner inconvenience nor related expenses.

Dakota Digital will cover the return standard freight once the product has been evaluated for warranty consideration, however the incoming transportation is to be covered by the owner.

This Warranty is in lieu of all other expressed warranties or liabilities. Any implied warranties, including any implied warranty of merchantability, shall be limited to the duration of this written warranty. No person or representative is authorized to assume, for Dakota Digital, any liability other than expressed herein in connection with the sale of this product.

**⚠WARNING:** This product can expose you to chemicals including lead, which is known to the State of California to cause cancer and birth defects or other reproductive harm. For more information go to [www.P65Warnings.ca.gov](http://www.P65Warnings.ca.gov)



**4510 W. 61st St. North**  
**Sioux Falls, SD 57107**  
[www.dakotadigital.com](http://www.dakotadigital.com)  
[dakotasupport@dakotadigital.com](mailto:dakotasupport@dakotadigital.com)

Phone (605) 332-6513  
Fax (605) 339-4106

© Copyright 2025 - Dakota Digital