

Remove Original POA Valve

Before removing photograph or note position of original POA valve, oil bleed line, equalizer tube, brackets and clamps.

- 1) If the A/C system contains refrigerant it will need to be removed and recovered by a qualified A/C service technician before beginning installation.
- 2) If original POA Valve is still on the vehicle disconnect Suction hose, equalizer tube from expansion valve and oil bleed line from evaporator core. Remove any clamps and/or hardware that secures valve in place. Loosen fitting at evaporator core and remove valve from vehicle.
- 3) Remove old O-rings and clean fittings that will be re-connected to new POA update assembly.

Install New Update Assembly.

NOTE: All O-rings must be lubricated with refrigerant oil before installation. When tightening fittings caution should be taken not to over torque fittings causing damage to threads or O-ring seals.

- 1) Place #12 O-ring on evaporator fitting.
- 2) Position assembly to align with equalizer tube and oil bleed line and secure with original clamp/hardware then hand tighten fitting to the evaporator.
- 3) Place #4 O-ring on equalizer tube from expansion valve and connect to update assembly.
- 4) Place #4 O-ring on oil bleed line from evaporator core and connect to update assembly.
- 5) Place #12 O-ring on hose assembly and connect hose to update assembly.
- 6) Re-Install original clamps and/or brackets if removed with original POA Valve.
- 7) Check and tighten all fittings.

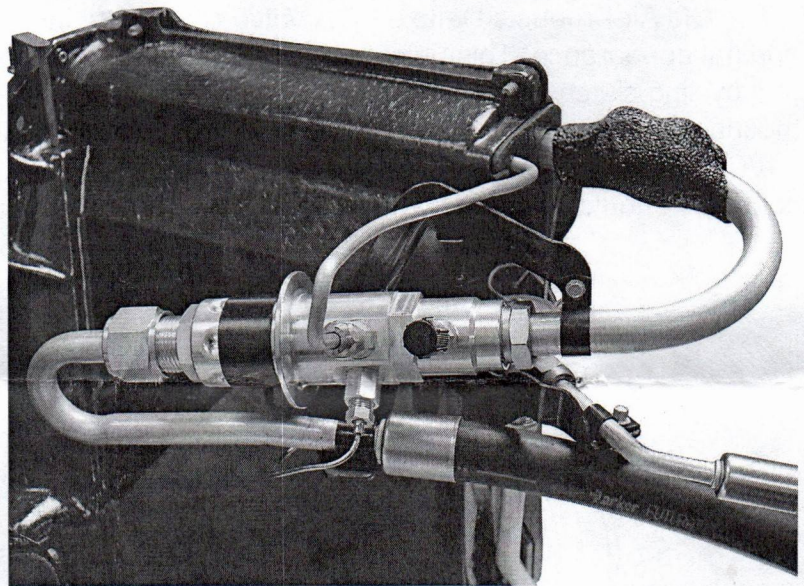

POA Update (Shown on 1967-72 Chevrolet Truck)

Deluxe POA Update

50-2551D & 50-2552D



1201 Forum Way South - Fort Worth TX 76140
(817) 531-2665 or FAX 817-531-2665
www.oldairproducts.com

Thank You for choosing Old Air Products as your A/C system parts supplier. We offer a full line of A/C and heater system replacement parts to complete your repair or restoration project including Evaporator Cores, Condensers, A/C Hose Assemblies, Expansion Valves, A/C Control Valves, Blower Switches, Relays, Resistors and many other A/C system components.

The Old Air Products Deluxe POA Valve Update Kit includes a machined assembly to retain an original appearance. This unique kit also includes a thermostat to convert the original A/C system to a cycling clutch system. Service ports are included for use with 134A or R12 refrigerant. Basic mechanical skills and knowledge of the A/C system operation is necessary for proper installation.

A/C system service for removal/recovery and charging system with refrigerant after installation is complete should be done by a qualified A/C service technician.

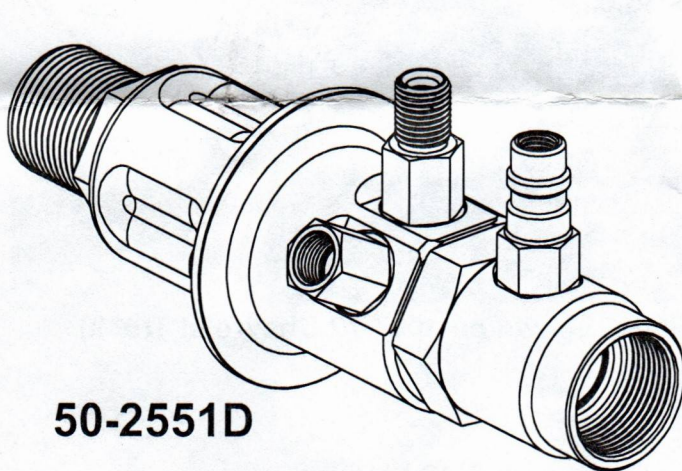

50-2551D

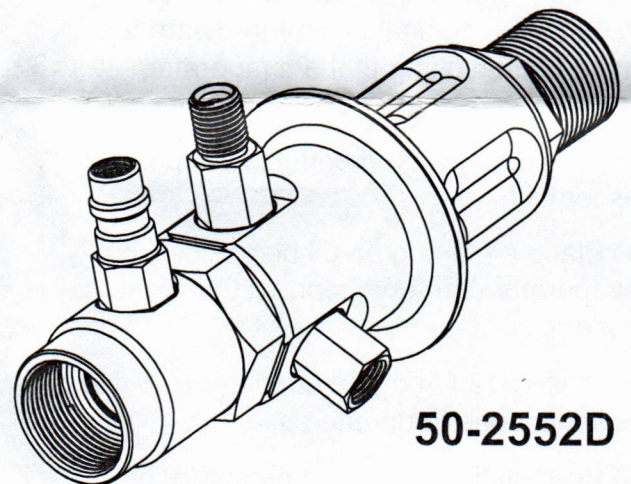

50-2552D

Compare POA Update to Original POA Valve

Make sure ports for the oil bleed line and equalizer tube for expansion valve are in the same position as your original POA valve.

The POA Update is assembled and supplied with a service port for 134a refrigerant. If using R12 refrigerant remove the 134a service port with a 9/16" wrench, lubricate O-ring and install R12 service port supplied in sack kit. Use caution not to over tighten and damage O-ring seal.

12) Connect wire harness to thermostat. (Photo 4)

13) Locate original wire that goes from control to compressor clutch and route green wires from thermostat to a location to be spliced/connected to original clutch circuit wire. (See Wiring Diagram)

14) Cut original clutch circuit wire and connect the two green wires to the cut ends of the clutch circuit wire using the 2 butt connectors provided. (See Wiring Diagram). *This will allow the thermostat to cycle compressor as evaporator temperature requires.*

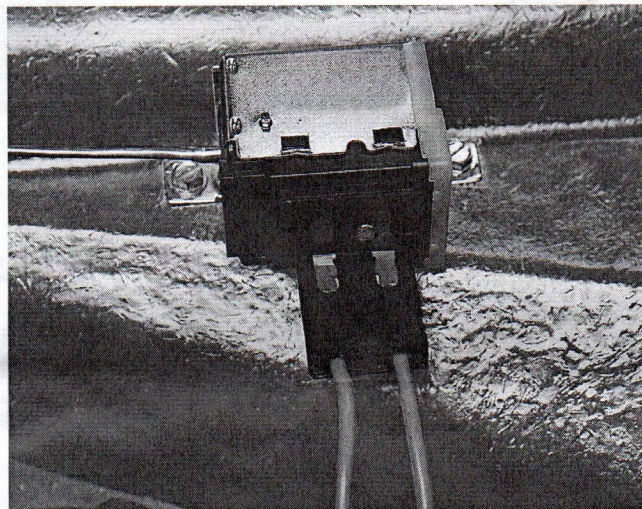
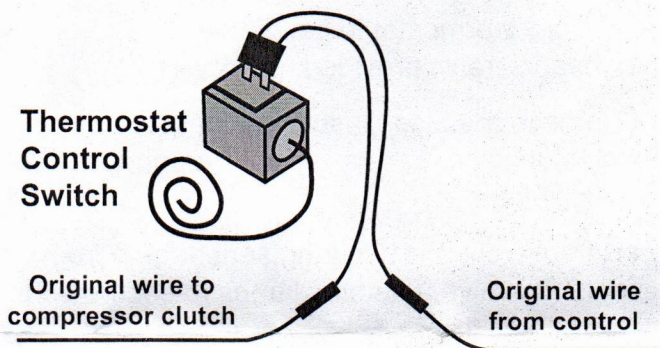

Photo 4 - Connect Wire Harness



Cut original clutch circuit wire and connect to the green wires from thermostat as shown

Wiring Diagram

Install Thermostat

- 1) Choose a location for the thermostat so capillary tube will reach the evaporator tube. (Photo 1) The most common mounting location for the thermostat is on the top, engine side of evaporator case.
- 2) When the thermostat location is determined mark location of mounting holes on the case.
- 3) Check to ensure that there is not any components inside the case that may be damaged by installation of mounting screws.
- 4) Drill two 1/8" mounting holes for thermostat. We recommend using a drill stop or masking tape to limit drill depth and prevent damage to internal components.
- 5) Secure thermostat to case with the 2) #8x3/8" hex head screws provided. (Photo 4)
- 6) Remove the black Insulating tape covering expansion valve sensor on the evaporator outlet (suction) tube.
- 7) Remove clamps securing sensor bulb from expansion valve. (Retain clamps to secure sensor tubes in step 10)
- 8) Clean tube, sensor bulb and clamps.
- 9) Gently make full 180 degree loop approximately 2 inches from end of thermostat sensor tube. Be careful not to kink sensor tube. (Photo 2)
- 10) Place expansion valve sensor bulb in original position, place thermostat sensor tube next to it and secure both sensors to evaporator inlet tube with original clamps. (Photo 2) NOTE: Surface of evaporator inlet tube and sensor bulbs must be clean. Expansion valve sensor bulb and thermostat sensor tube must be tight and have full contact with evaporator tube to work properly. (If original sensor clamp is damaged or won't fit a worm gear hose clamp can be substituted.)
- 11) Wrap evaporator inlet tube and sensors with Black Tacky Tape provided. (Photo 3) Make sure sensors are completely covered and insulated.

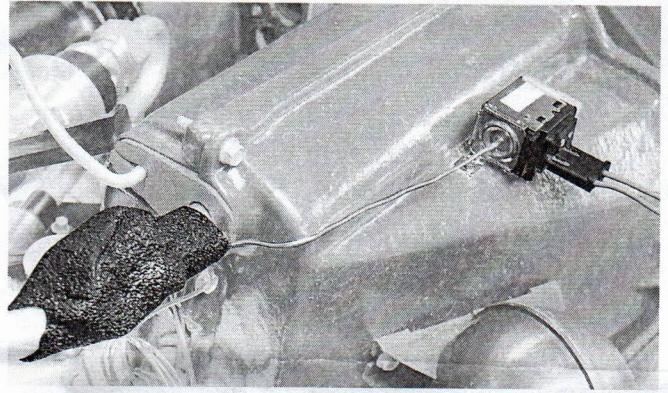

Photo 1 - Install Thermostat

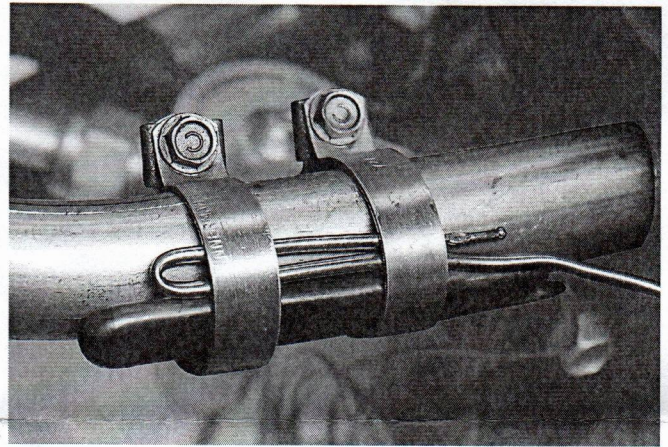

Photo 2 - Secure Sensors with Clamps



Photo 3 - Wrap Sensors with Insulating Tape