



*Professional Grade Suspension*

## Installation Instructions (X-0012)

### Aldan American, Road Comp Series - Front Coilover Conversion Kit

Item #	Part #	Description	QTY
1	AS-8XX	Phantom Series Coil-Over Shock	2
2	10XXXUSX	Conical Coil-Spring (Black)	2
3	ALD-16	GM 3.5" T-Bar Mount, Set	1
4	71006	Lower GM T-Bar Hardware Kit	1
5	ALD-50	One Piece Spring Retainer Assembly	2

\*This kit is designed to replace your front factory shocks and springs to a coilover shock system on select cars & trucks

\*The user understands that Aldan is not responsible for any direct or indirect use or misuse of any Aldan product. Specialized equipment and race parts within this kit are exposed to varied conditions based on how they are installed and used by the user. A professional shop and installer is recommended for all Aldan products. Aldan is not responsible for fitment issues outside the OEM mount locations (Exhausts, Aftermarket Axles, Sway Bars, Fuel Cells, etc.). Use proper safety equipment along with jacking locations and jack stands at all times when installing. Aldan shall not be liable for any claims, injuries, actions or causes of action with the use of any Aldan product.

\*Recommended Tools: Floor jack or vehicle lift (User proper jacking locations per the manufacturer). Jack Stands, Tire chalk, Toque Wrench, Basic Hand Tools

Visit [www.aldanamerican.com](http://www.aldanamerican.com) for additional guides, video and installs updated regularly.



**WARNING:** Cancer and Reproductive Harm - [www.P65Warnings.ca.gov](http://www.P65Warnings.ca.gov)

## Road Comp, Front Coilover Kit Installation Instructions

- Prior to disassembly measure and record the ride height at all four corners on a flat level surface. This is the only way to determine that the vehicle is level before disassembling. (Fig. 1)
- Follow the use of personnel safety precautions and protection.
- Jack vehicle up and use jack stands under the frame rails to safely support it.
- Remove the front wheels.
- Remove the front shocks and coil springs. Follow a service manual if necessary.
- Loosen the lower A-arm bolts so the A-arm moves freely.
- Drill out the lower shock mounting holes to 3/8" if necessary. Check fit the lower T-bar to the lower A-arm. The inside edges may need to be filed to fit the flats on the T-bar. Remove the lower nuts from the A-arm.
- Assemble the coil springs on the shocks. Anti-seize compound is necessary on spring seat adjusting threads to prevent them from seizing.
- Install the upper shock bushings and allow front coil over shock to hang. Do not tighten yet. Make sure the upper spring is located in the spring pocket. Fig. 2
- Put the 3/8" bolts and washers in the T-bar with the threads pointing down.
- Bring the lower A-arm up to the T-bar and attach the nuts from the underside. The shock will now be bolted to the topside of the A-arm. Torque shock bolts to 35 ft. lbs.
- Reassemble the front suspension. Fig. 3
- Reinstall wheels and place your car back on the ground.
- With the wheels on the ground, the upper shock bushings can now be tightened.
- Measure and compare new height with the previously recorded height.
- To adjust the ride height, support with frame on jack stands with the A-arms at droop turn the adjusting collars using a spanner wrench (Aldan P/N ALD-1). Loosen the spring seat to lower or tighten to raise height.
- After ride height is set torque the lower control arm bolts to 75 Ft. lbs. with wheels on the ground.
- To adjust the compression dampening turn the adjuster knob counter clockwise to soften or clockwise to increase the dampening. The knob turns all the way around with not stop.
- *Your vehicle will require that the front-end alignment is checked by a qualified wheel alignment specialist.*



Fig. 1



Fig. 2

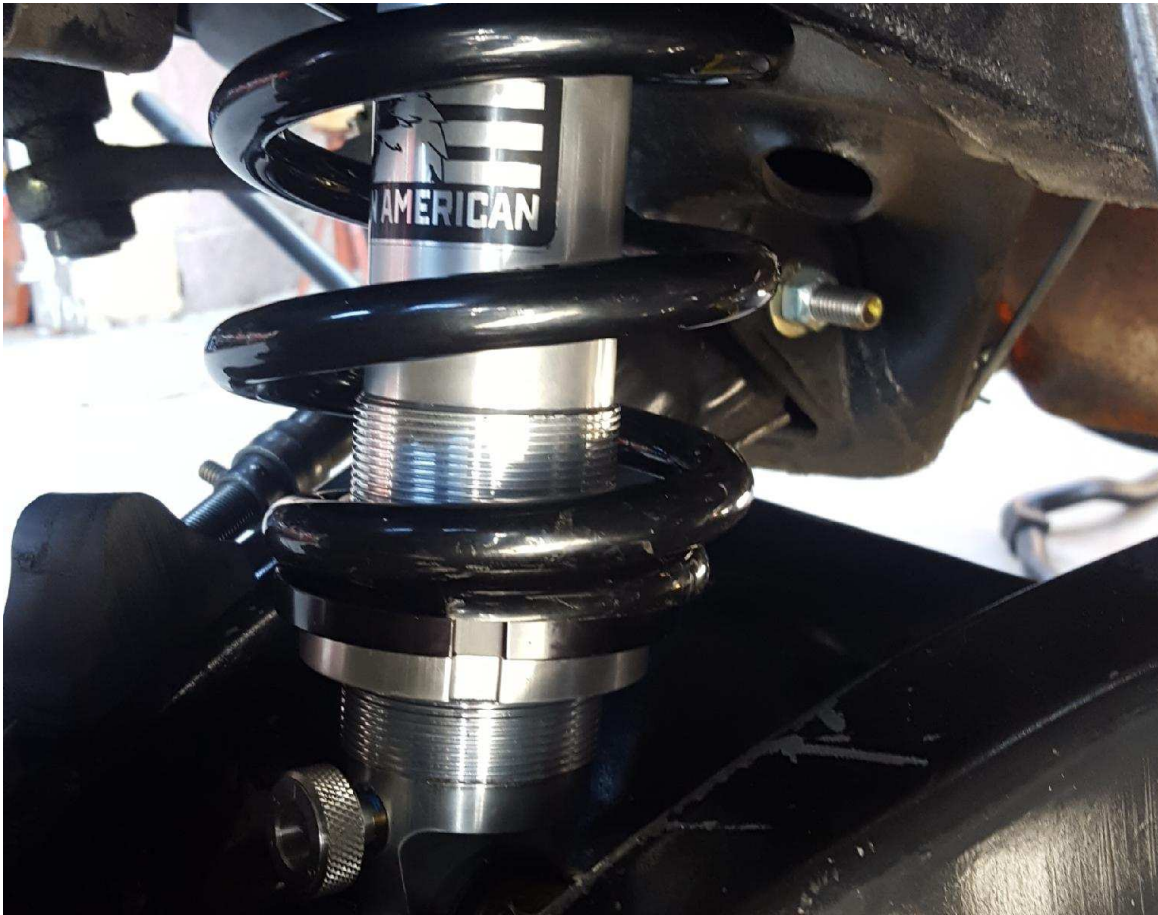

Fig. 3





# (X-0016) SHOCK ABSORBER INSTALLATION GUIDE

There are four common basic causes of service problems:

- Misalignment
- Bottoming
- Incorrect angularity
- Insufficient clearance

If you will pay particular attention to these problem areas as you follow the installation procedures described below, you will ensure maximum performance and prolong the life of your Aldan American adjustable shock absorbers.

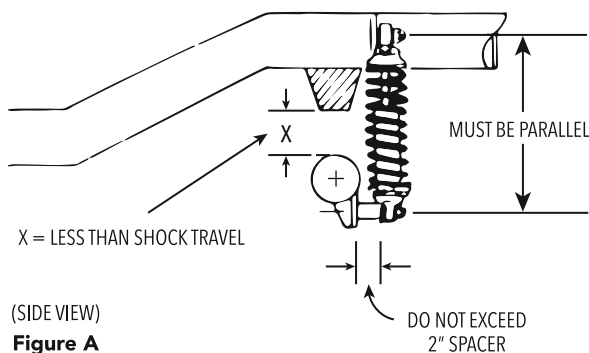

(SIDE VIEW)  
**Figure A**

## ALIGNMENT

The centerlines of shock mounting studs must be parallel to each other (Figure A). If shocks are installed on misaligned mounting studs, excessive shock bushing wear will result; in cases of extreme misalignment, shocks may break or suffer other permanent damage. This is the most common cause of shock absorber failure.

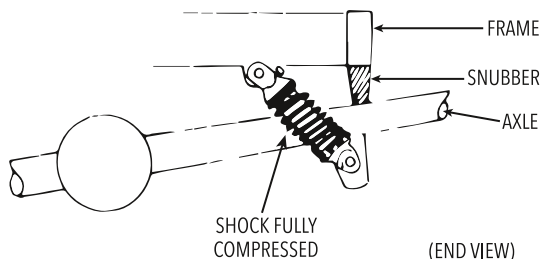

(END VIEW)  
**Figure B**

## SHOCK TRAVEL

Suspension components must bottom out before the shock absorber bottoms. This means the axle must contact the frame snubber before the shock is fully compressed (Figure B). If the shock absorber bottoms first, damage to the shock or mounting bracket may occur.

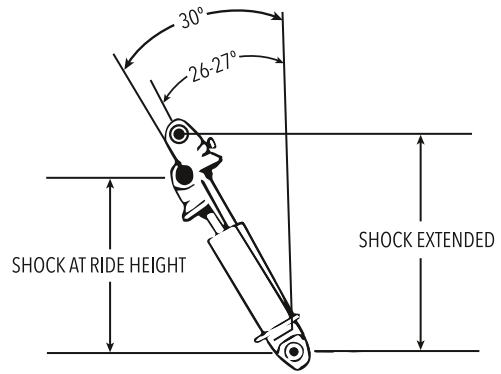

**Figure C**

## MOUNTING ANGLE

The more vertical the shock, the firmer the ride; the less vertical, the softer the ride (but less support, especially on cornering). We recommend a mounting angle of 30 degrees from true vertical at ride height. Generally speaking, the weight of the car will collapse the shock 1-1/4 to 1-1/2 inches at ride height. Using this rule of thumb, you will achieve a 30 degree angle at ride height if the shock is mounted at 26 to 27 degrees when it is fully extended (Figure C). When designing your suspension mounting points, extend the shock to 2/3 at ride height; i.e.. if stroke is 3 inches, set the car up so that at ride height, the shock has room for 2 inches compression and 1 inch rebound. Do not design your suspension with the shock fully extended and the car at rest—allow it to sag, otherwise damage from excessive rebound force may occur.

## CLEARANCE

When mounting coil-over shocks, be sure to allow adequate clearance between coil springs, spring retainer rings and frame or body components. If coil springs or retainer rings contact moving frame or body components, breakage of shock absorber, springs or retainer rings may occur.

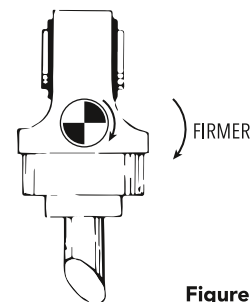

**Figure D**

## SHOCK ADJUSTMENT

The Aldan American adjustable shock has six valve damping positions, so you may dial in the ride you like. To increase firmness, rotate the adjusting knob (located at the top of the shock absorber) clockwise. When the knob is rotated all the way out (counterclockwise), the shock damping is at its softest setting (Figure D).